

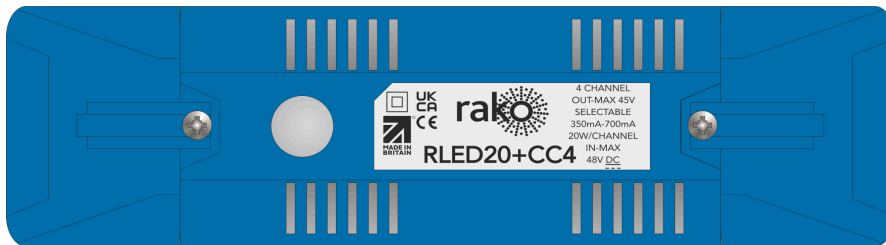

## Instruction Manual

# RLED20+CC4

4 Channel Constant Current LED Dimmer Module



2024  
Version 2.0.0



For more information relating to the RLED20+CC4, see the [Wireless Module Application Sheet](#), [Wireless RAK Application Sheet](#), and [Wireless Device LED Diagnostics](#).

## Contents

[1 What is the RLED20+CC4?](#)

[2 Loadings](#)

[3 Installation of the RLED20+CC4](#)

[4 Initial checks](#)

[5 Programming the RLED20+CC4](#)

[Appendix 1: Example wiring diagram](#)

[Appendix 2: LED Diagnostics](#)

## 1 What is the RLED20+CC4?

- The RLED20+CC4 is a Constant Current LED dimmer with four outputs designed for controlling four independent Constant Current loads.
- Offering various output options, the RLED20+CC4 supports 350mA, 500mA, and 700mA loads.
- As well as being compatible with Rako Wireless systems, the RLED20+CC4 can also be integrated into a Wired system when within range of a WK-HUB.

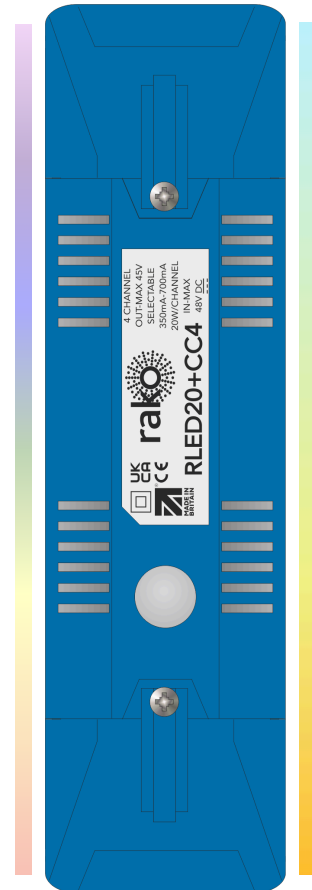

## 2 Loadings

The permissible loadings depend on several criteria keeping within the loadings of 20W per Channel and a forward Voltage of 45V.

Min Load	Max Load
3W	20W per Channel

To calculate the total forward voltage of the load, refer to the manufacturer's data.

### 3 Installation of the RLED20+CC4

#### **⚠ WARNING**

Installation should only be carried out by a competent electrician.  
**DO NOT CONNECT DIRECTLY TO THE MAINS SUPPLY.**

- All LED fittings should be wired in series.
- RLED20+CC4 modules should be mounted in areas that are adequately ventilated, dry, and outside of any enclosed metal casings that may interfere with the Wireless signal.
- Modules should be mounted vertically, with the terminals at the bottom, or horizontally.
- While the modules are designed to be maintenance-free, they should be mounted in an accessible location should investigation or re-addressing of the units be necessary.
- Ensure that the cable clamps are fitted tightly to secure the cables.
- The unit input Voltage is 48VDC, this is not supplied with the unit and must be purchased separately.

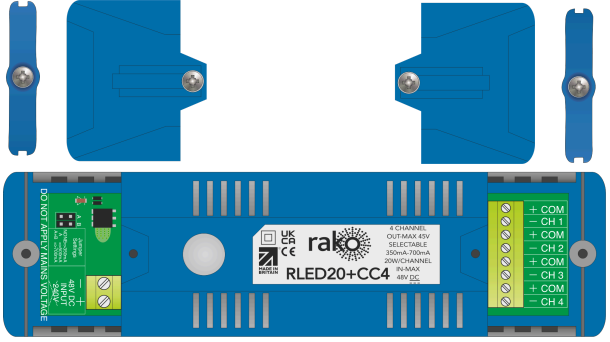
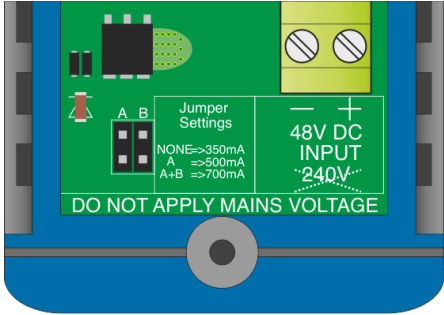
<p>STEP 1</p>		<p>Remove the covers and cable clamps.</p>						
<p>STEP 2</p>		<p>Select the Constant Current output on the RLED20+CC4 to match the rating on the load.</p> <table border="1" data-bbox="1007 1682 1378 1883"> <tr> <td>NONE</td> <td>350mA</td> </tr> <tr> <td>A Jumper</td> <td>500mA</td> </tr> <tr> <td>A+B Jumper</td> <td>700mA</td> </tr> </table>	NONE	350mA	A Jumper	500mA	A+B Jumper	700mA
NONE	350mA							
A Jumper	500mA							
A+B Jumper	700mA							

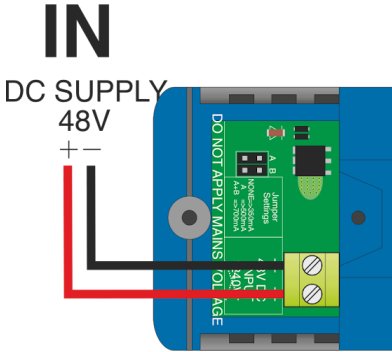
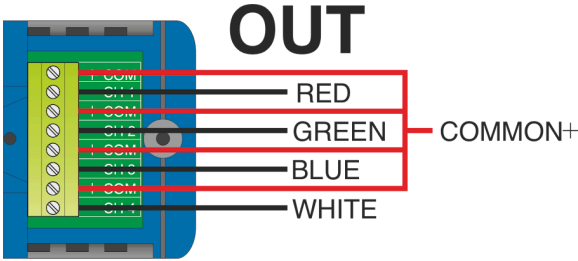
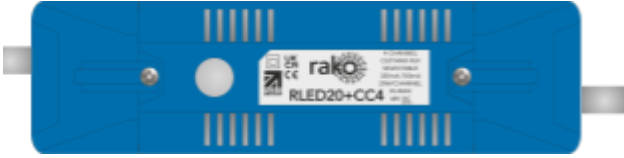
STEP 3	 <p><b>IN</b> DC SUPPLY 48V + -</p>	Connect the 48VDC input supply.
STEP 4	 <p><b>OUT</b> RED GREEN BLUE WHITE COMMON+</p>	<p>Connect the load, there can be up to four controllable outputs.</p> <p><b>NB</b> Ensure that the connected load is wired in series, as parallel wiring will cause damage to the RLED20+CC4 and the load.</p>
STEP 5		Fix the cable clamps over the cables to secure them in place, and replace the cover.

## 4 Initial checks

- When power is initially connected to the module, the load should power up to full brightness.
- The clear button can be used as a manual on/off switch to test the circuit.
- The internal LED behind the clear button will flicker when the module receives any Rako Wireless message and is a useful diagnostic indicator. The LED feedback becomes inactive after 20 minutes to avoid a nuisance light spill but can be re-activated by pressing the clear button.

## 5 Programming the RLED20+CC4

Once the RLED20+CC4 has powered up and has been tested working with the setup button, the device is ready to be programmed. For instructions on how to program the RLED20+CC4, see the [Wireless Module Setup Guide](#).



Thank you for choosing Rako Controls; we hope that you are pleased with your system. Should you require further assistance, please contact us via our website, [www.rakocontrols.com](http://www.rakocontrols.com), or by calling our customer support helpline on 01634 226666.

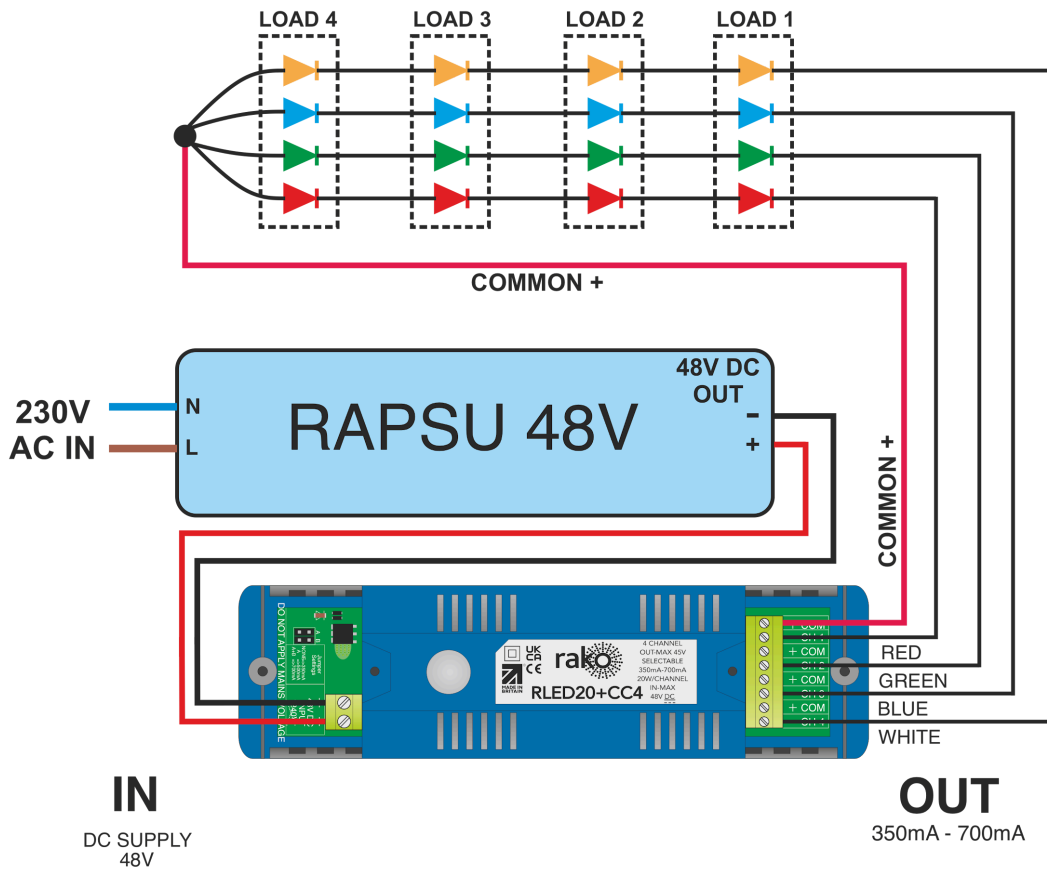

## Appendix 1: Example wiring diagram



## Appendix 2: LED Diagnostics

Wireless Range	LED Pulses	Description
Good Wireless reception		When the unit is receiving successfully, there will be four rapid pulses on the LED when any Wireless message is sent.
Bad Wireless reception		When the unit is out of range, there will be intermittent pulses on the LED when any Wireless message is sent.  NB It is recommended to install a Wireless repeater (WRB-100) if you are experiencing intermittent Wireless range.